

AS-6M30-HC BLACK 320W~340W MONOCRYSTALLINE MODULE

ADVANCED PERFORMANCE & PROVEN ADVANTAGES

- High module conversion efficiency up to 20.15% by using innovative Half-cell design and five busbar cell technology.
- Low temperature coefficient and excellent performance under high temperature and low light conditions.
- Robust aluminum frame ensures the modules to withstand wind loads up to 2400Pa and snow loads up to 5400Pa.
- High reliability against extreme environmental conditions (passing salt mist, ammonia and hail tests).
- Potential induced degradation (PID) resistance.
- Positive power tolerance of 0 ~ +3 %.
- Aesthetically appealing design with black backsheet and frame.

CERTIFICATIONS



- IEC 61215, IEC 61730, UL 1703, IEC 62716, IEC 61701, IEC TS 62804, CE, CQC, ETL(USA), JET(Japan), J-PEC(Japan), KS(South Korea), BIS(India), MCS(UK), CEC(Australia), CSI Eligible(CA-USA), Israel Electric(Israel), InMetro(Brazil), TSE(Turkey)
- ISO9001:2015: Quality management system
- ISO14001:2015: Environmental management system
- ISO 45001:2018: Occupational health and safety management system

SPECIAL WARRANTY

- 20 years product warranty
- 30 years linear power output warranty

Passionately
committed to
delivering innovative
energy solution

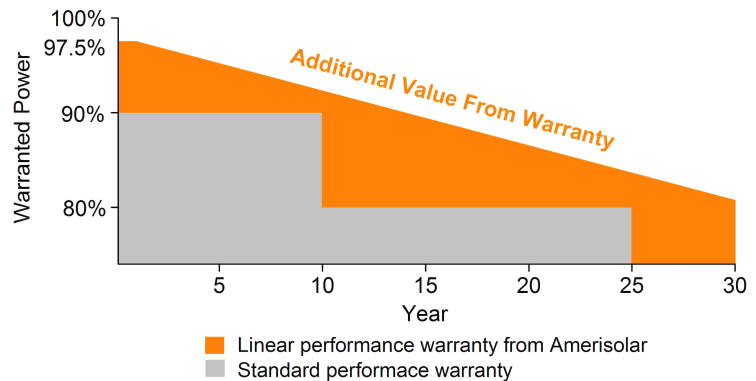

ELECTRICAL CHARACTERISTICS AT STC

Maximum Power (P_{max})	320W	325W	330W	335W	340W
Open Circuit Voltage (V_{OC})	40.2V	40.4V	40.6V	40.8V	41.0V
Short Circuit Current (I_{SC})	10.14A	10.22A	10.30A	10.38A	10.46A
Voltage at Maximum Power (V_{mp})	33.4V	33.6V	33.8V	34.0V	34.2V
Current at Maximum Power (I_{mp})	9.59A	9.68A	9.77A	9.86A	9.95A
Module Efficiency (%)	18.96	19.26	19.56	19.85	20.15
Operating Temperature	-40°C to +85°C				
Maximum System Voltage	1000V DC/1500V DC				
Fire Resistance Rating	Type 1(in accordance with UL1703)/Class C(IEC61730)				
Maximum Series Fuse Rating	20A				

STC: Irradiance 1000W/m², Cell temperature 25°C, AM1.5

ELECTRICAL CHARACTERISTICS AT NOCT

Maximum Power (P_{max})	239W	243W	247W	251W	255W
Open Circuit Voltage (V_{OC})	37.2V	37.4V	37.6V	37.8V	38.0V
Short Circuit Current (I_{SC})	8.22A	8.29A	8.36A	8.43A	8.50A
Voltage at Maximum Power (V_{mp})	30.4V	30.6V	30.8V	31.0V	31.2V
Current at Maximum Power (I_{mp})	7.87A	7.95A	8.02A	8.10A	8.18A

NOCT: Irradiance 800W/m², Ambient temperature 20°C, Wind Speed 1 m/s

MECHANICAL CHARACTERISTICS

Cell type	Monocrystalline
Number of cells	120 (6x20)
Module dimensions	1684x1002x35mm (66.30x39.45x1.38inches)
Weight	18.5kg (40.8lbs)
Front cover	3.2mm (0.13inches) tempered glass with AR coating
Frame	Anodized aluminum alloy
Junction box	IP68, 3 diodes
Cable	4mm ² (0.006inches ²), Portrait: 300mm (11.81inches); Landscape: 1150mm (45.281inches)
Connector	MC4 or MC4 compatible

TEMPERATURE CHARACTERISTICS

Nominal Operating Cell Temperature (NOCT)	43°C±2°C
Temperature Coefficients of P_{max}	-0.36%/°C
Temperature Coefficients of V_{OC}	-0.28%/°C
Temperature Coefficients of I_{SC}	0.05%/°C

PACKAGING

Standard packaging	31pcs/pallet
Module quantity per 20' container	372pcs
Module quantity per 40' container	806pcs(GP)/884pcs(HQ)

ENGINEERING DRAWINGS

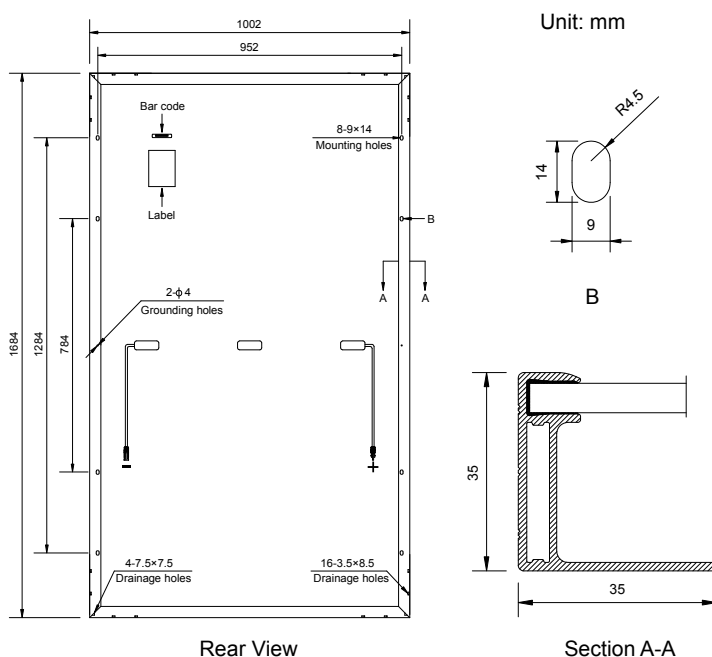

IV CURVES

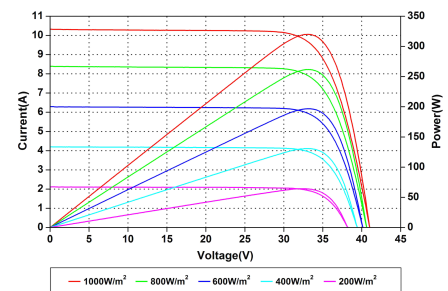

Current-Voltage and Power-Voltage Curves at Different Irradiances

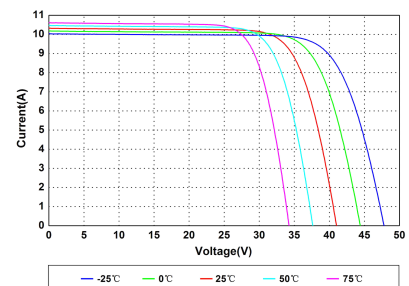

Current-Voltage Curves at Different Temperatures

Specifications in this datasheet are subject to change without prior notice.